

ROTARY CYLINDER

SRJN-16, 20, 25, 30, 40



특징 (Character)

- 키를 사용하지 않은 TABLE 연결방식
Table connect type in unused key
- WEARING 장착으로 내구성 향상
Durability improvement by built in wearing
- 저마찰 PACKING 사용으로 낮은 회전저항
Low rotation resistance through using low-friction packing
- STOPPER 에 의한 각도 조절이 용이 (ABSORBER 부착가능)
Ease to adjust angle by stopper (possible to attach absorber)
- RACK & PINION 구조의 경제적인 ROTARY CYLINDER
Economical rotary cylinder of rack & pinion structure
- ABSORBER 선택가능
Possible to select absorber



랙 & 피니언방식 (Rack & pinion type)

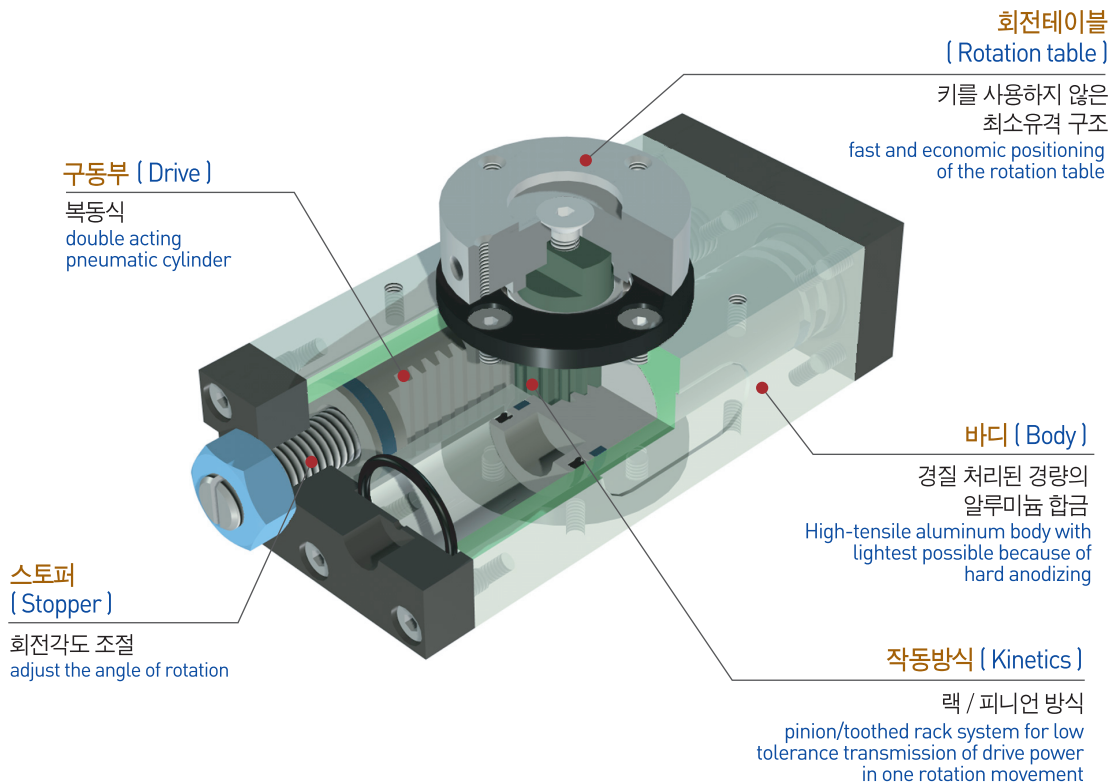

부품분해도 (Exploded view)

※ 본 분해도는 한 제품을 예시하였으므로 기종별로 차이가 있을 수 있습니다.
 ※ This is exploded view illustrates a certain product only. The contents may vary by product models.

- SRJN
- SDRJ
- RJC
- RTU
- SSU
- MSRJ

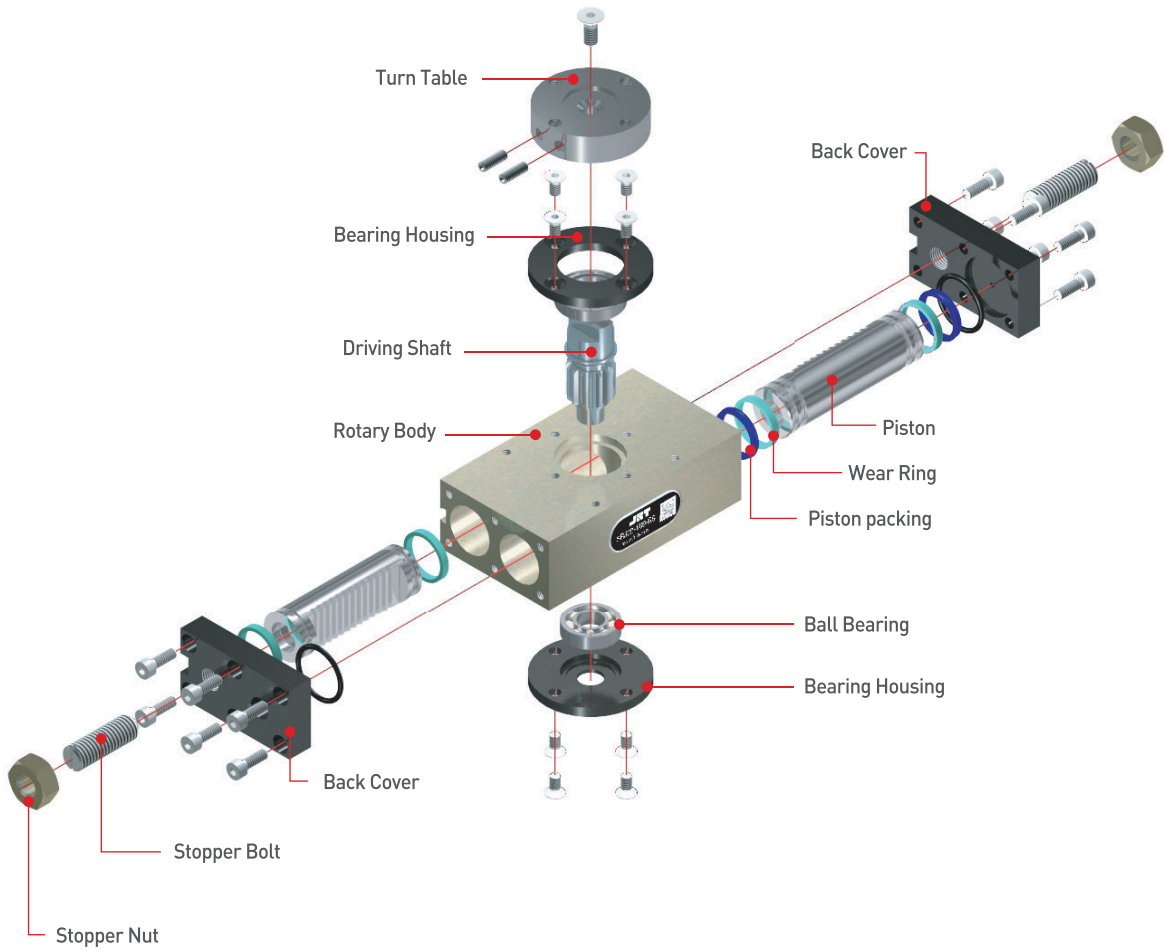

주문기호 (Ordering Code)



완충기
Shock Absorber

무기호 - 스톱퍼
 DA - 조절형타입 속압쇼바
 DN - 비조절형타입 속압쇼바
 * 제품에 부착되는 속압쇼바 사양 및 치수는 속압쇼바 상세 페이지를 참조 바랍니다.

*Note
 SRJ16-M10 x P1.0 (조절형 속압쇼바 부착 불가)
 (Adjustable type shock absorber is not applicable)
 SRJ20-M10 x P1.0 (조절형 속압쇼바 부착 불가)
 (Adjustable type shock absorber is not applicable)
 SRJ25-M14 x P1.5 SRJ30-M14 x P1.5
 SRJ40-M20 x P1.5

Nil- Stopper
 DA - Adjustable Type
 DN - Non Adjustable Type
 * For the specification of shock absorber attached to the product and the shock absorber dimension, refer to details of shock absorber part.

회전각도
Turning Angle

90° - (90°) : 표준
 180° - (180°) : 표준
 각도 옵션 적용시 회전 방향 설정 하여 통보 바랍니다.

90° - (90°) : Standard
 180° - (180°) : Standard
 - For angle Option, inform us setting direction of rotation

제품명
Product Name

실린더직경
Bore Size
16, 20, 25, 30, 40

SRJN - 16 - 180 - RS - 1 - 3M - DA - 1

센서명칭
Sensor Type

무기호 - 센서 및 관련부품을 제공하지 않습니다.
 RS(기존방식) 기입시, 본사에서 적합한 임의의 센서를 선정하여 부착해 드립니다.

* 제품에 부착 가능한 센서 규격 및 주문기호는 센서 상세 페이지를 참조 바랍니다.

Nil - Sensor and relevant components are not supplied.
 When entering RS(existing method), our Head Office will attach a suitable sensor selected at its option.

* For the specification of sensor attachable to the product and the sensor order code, refer to details of sensor part.

센서수량
Number of Sensor

1 - 1개
 무기호 - 2개

1 - 1pc.
 Nil - 2pcs.

센서 선 길이
Sensor Cable Length

무기호 - 1m
 3M - 3m
 5M - 5m

Q□ - 커넥터 사용
 * 커넥터 사양 및 기능여부는 센서 상세 페이지를 참조 바랍니다.

Nil - 1m
 3M - 3m
 5M - 5m

Q - Quick connector
 * For the specification of connector and availability, refer to details of sensor part.

완충기수량
Number of Absorber

1 - 1개
 무기호 - 2개

1 - 1pc.
 Nil - 2pcs.

▣ 제품사양 (Specification)

P=공기압력(bar)
P=Air Pressure(bar)

SRJN
SDRJ
RJC
RTU
SSU
MSRJ

제품명칭 Products Name	SRJN16	SRJN20	SRJN25	SRJN30	SRJN40	단위 Unit
실효토크 Actual Torque	0.093P	0.184P	0.327P	0.608P	1.480P	N.m
축직각하중 Radial payload	0.8	1.2	3.5	5.7	15	kg
축방향 압축하중 Compress load(thrust)	0.8	1.2	3.5	5.7	15	kg
축방향 인장하중 Tensile load(thrust)	0.6	1.0	3.0	4.5	8.0	kg
제품중량 (90°) Weight (90°)	0.41	0.63	1.17	2.08	3.61	kg
제품중량 (180°) Weight (180°)	0.47	0.80	1.37	2.45	4.33	kg
회전시간 (90°) Turning time (90°)	0.2 to 0.5	0.2 to 0.8	0.2 to 1.0	0.3 to 1.0	0.3 to 1.0	sec
회전시간 (180°) Turning time (180°)	0.3 to 0.7	0.3 to 1.0	0.3 to 1.5	0.5 to 1.5	0.5 to 1.5	sec
배관접속구 Fitting size	M5	PF(G) 1/8	PF(G) 1/8	PF(G) 1/8	PF(G) 1/8	
공기소모량 (90°/180°) Air consumption (90°/180°)	3.8 / 7.6	7.4 / 14.8	13.1 / 26.2	24.3 / 48.6	59.2 / 118.4	cm ³
완충장치 Cushion	스토퍼 or 압소바 Stopper or Absorber					
반복위치정밀도 Repetition Accuracy	±0.1					degree
사용압력 Operating pressure	3 to 7					bar
주위온도 Ambient temperature	-5 to 60					°C
윤활 Lubrication	불필요 Needless					

반복정밀도 : 연속100회 작동 후 측정치
* After 100 consecutive strokes to end positions

▣ NOTE

SRJN-16

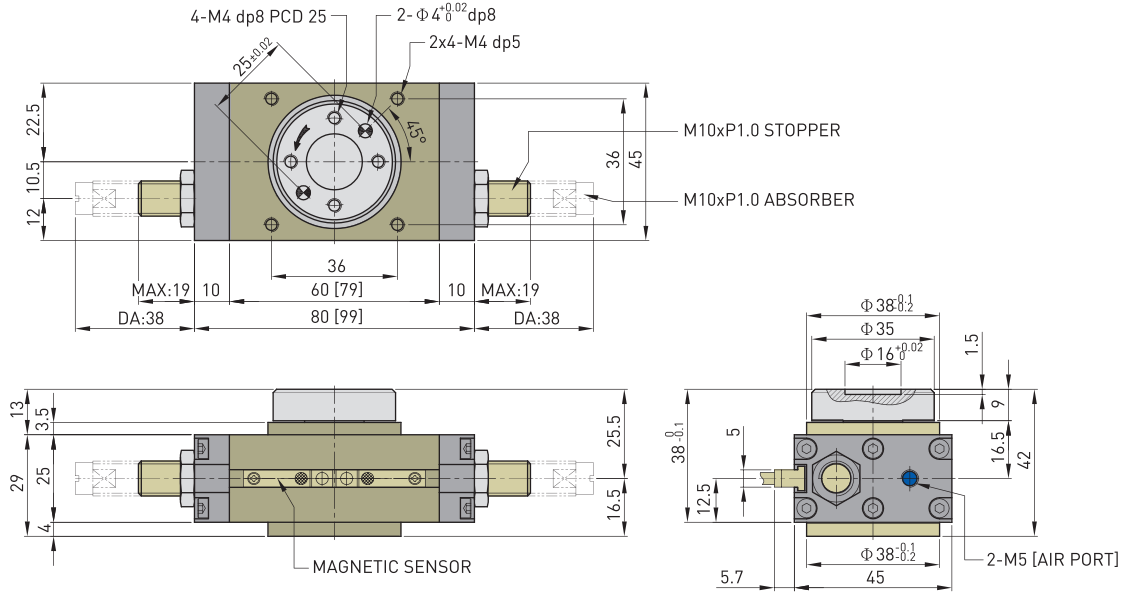

* () 안 치수는 180°
for () in number 180°

SRJN-20

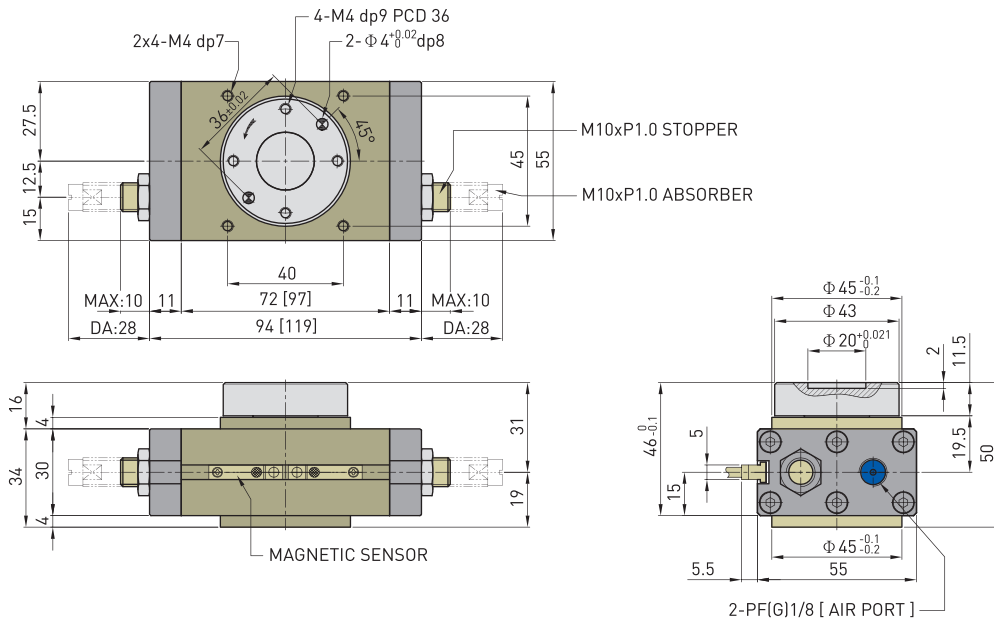

* () 안 치수는 180°
for () in number 180°

SRJN-25

SRJN
SDRJ
RJC
RTU
SSU
MSRJ

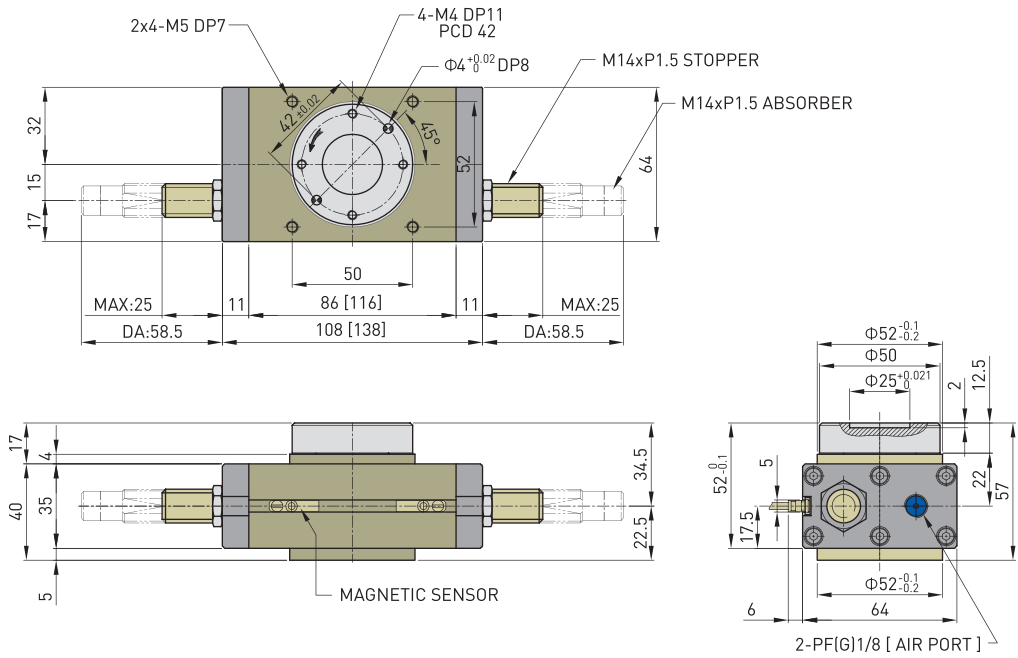

* []안 치수는 180°
for [] in number 180°

SRJN-30

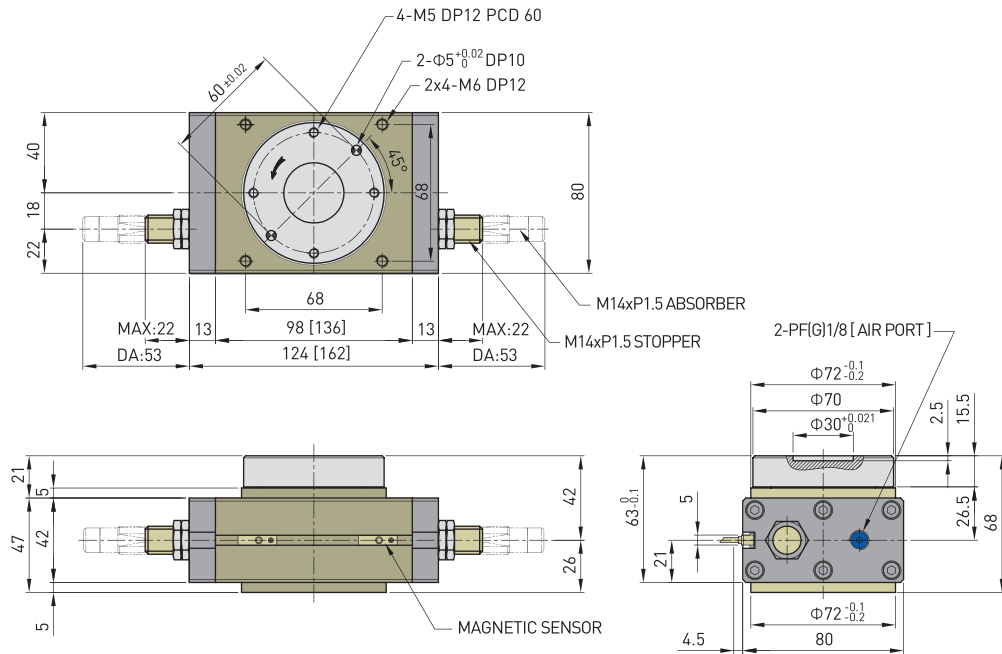

* []안 치수는 180°
for [] in number 180°

SRJN-40

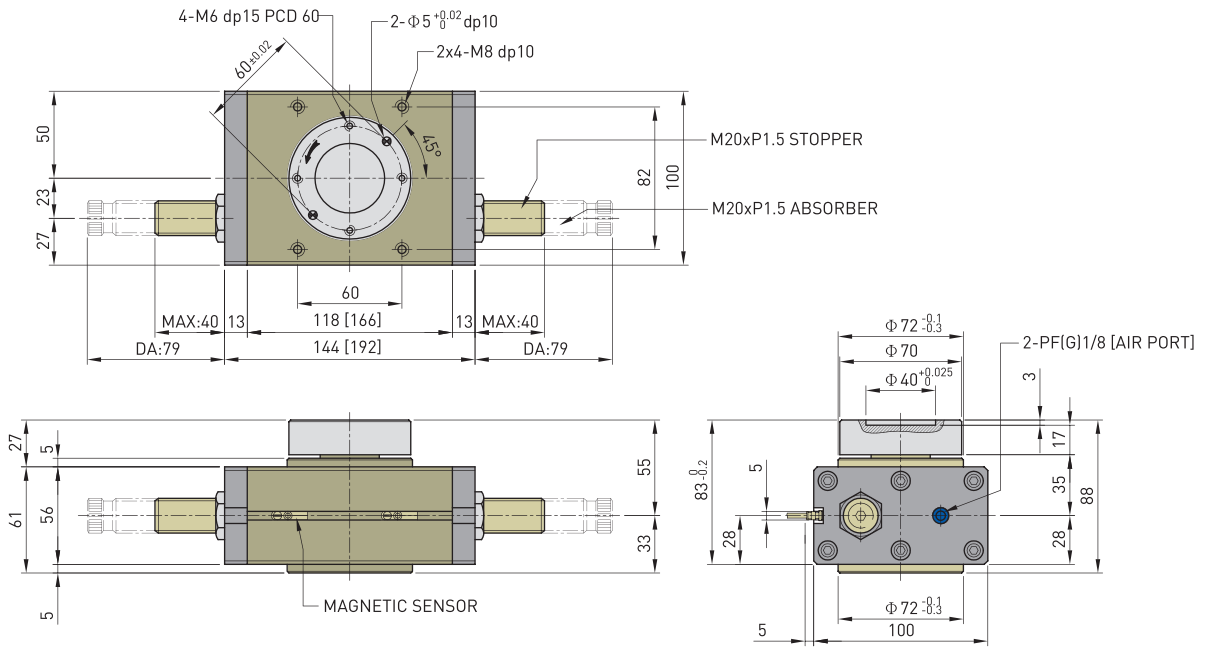

* () 안 치수는 180°
for [] in number 180°

NOTE